

Water Specialist Cabinet

Clack has developed a water softener cabinet that will accept any WS1 or WS1.25 control valve model.

Its top sliding cover opens to a large tapered chute for ease of adding salt to the system without removing the cover. This new design offers a unique flip up access window that allows you to do valve programming without removing the cover.

A new brine valve/brine well system has been incorporated in the design that allows full access to the brine valve system for servicing without having to disassemble the complete system.



Top sliding cover and flip up access window



Brine valve/brine well system

The cabinet will be available for use with 18" and 35" tall media tanks including a 12" x 35" tank to maximize resin capacity. Control Valve and Mineral Tank not included.

Water Specialist - CWS-18 Cabinet

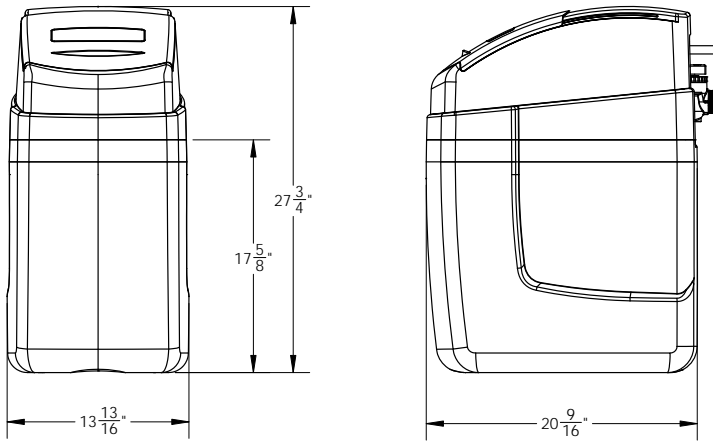

The Water Specialist - CWS-18 Cabinet accepts 18" tall mineral tanks.

Water Specialist - CWS-35 Cabinet

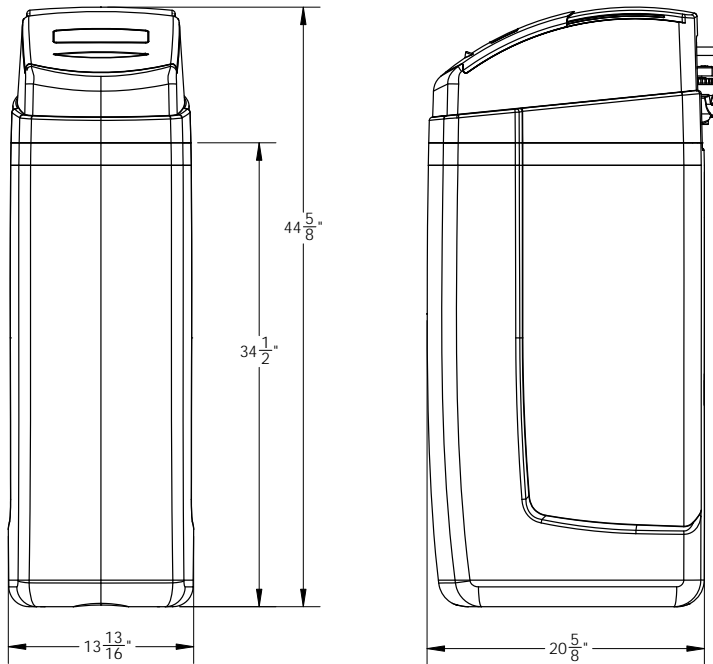

The Water Specialist – CWS-35 Cabinet accepts 35" tall mineral tanks up to a 12" diameter to maximize system capability.

ORDERING INFORMATION

The cabinet requires **two** part numbers when ordering, one part number for the base assembly with the brine system and one part number for the top trim plate and the cover assembly.

ORDER NUMBER	DESCRIPTION	QUANTITY PER CARTON	WEIGHT PER CARTON
J2TCWS-HEH	CWS Top Assembly Light Gray/Dark Gray	1	8 lbs.
J2TCWS-BEB	CWS Top Assembly Light Gray/Blue	1	8 lbs.
J2B18E	CWS18 Bottom Assembly Light Gray with 474 Assembly	1	10 lbs.
J2B35E	CWS35 Bottom Assembly Light Gray with 474 Assembly	1	17 lbs.